

# PYROELECTRIC IR SENSOR THERMOPILE SENSOR

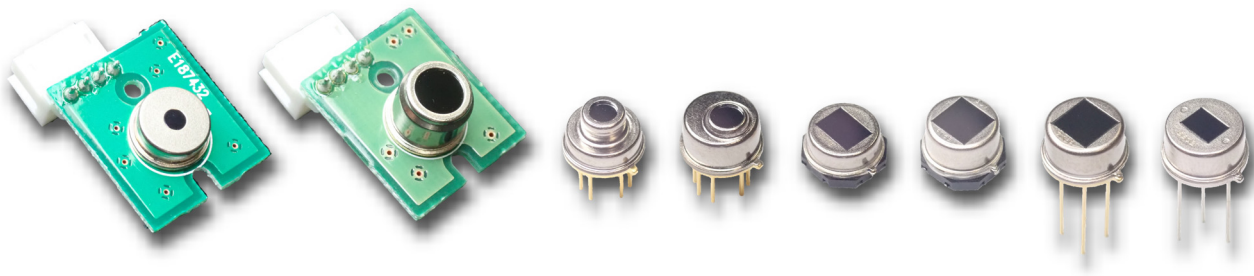

We Make Good World with Sensor



# Application Guide

## Pyroelectric IR sensor

The pyroelectric infrared sensor is an infrared sensor that applies the pyroelectric effect of ferroelectric ceramic. It can detect human body movement and so on with sensing temperature changes.



### Lighting

Automatic switch control.  
Energy saving, Comfort & Convenience.



### Security

Security & Safety.



### Air-conditioner

Comfort & Energy saving.



### IP camera IoT

Camera control. Energy saving & battery life extension. Security, Surveillance & Pet monitor.



### Toilet

Automatic toilet lid open and close. Comfort, Convenience & Cleanliness.



### TV

Automatic display control.  
Energy saving & comfort.

# Thermopile sensor Thermopile sensor unit

Thermopile sensor is an infrared sensor that applies the Seebeck effect. With detecting absolute thermal amount of the object, it measures temperature without contact.



**Printer**

Temperature monitor of inside parts. Printing quality and efficiency improvement.



**Automotive**

Temperature measurement of seat space, passenger, heat generation parts and etc..  
Comfort and safety improvement.



**Microwave oven**

Food temperature measurement. Heat control to preset temperature.



**Air-conditioner**

Temperature monitor of floor and human body. Comfortability control & energy saving control.



**IH cooker**

Temperature monitor of pot bottom. Automatic control of cooking temperature.



**Ear thermometer**

Quick measure of body temperature.

	Application						Object (Target temperature )	Part number	Number of element	FOV [°]		Shape	Output method	Feature	Data sheet
	Air-conditioner	Microwave oven	IH cooker	Printer	Ear thermometer	Non-contact thermometer				X-axis	Y-axis				
	○						Floor temperature (-20~60°C)	A3D01S-FB-50-60	1	90	90	TO-5 detector	SMBus	* Wide-angle detection	<b>5</b>
	○						Floor temperature (-20~60°C)	A1D08A-BU-50-60	8 (8x1)	44	5	TO-5 detector	SMBus		<b>7</b>
	○						Floor temperature (-20~60°C)	A1D16B-AU-50-60	16 (4x4)	88	88	TO-5 detector	SMBus		<b>8</b>
		○					Food (-20~120°C)	A1D01S-AU-50-120	1	22	22	TO-5 detector	SMBus		
		○					Food (-20~120°C)	A1D08A-BU-50-120	8 (8x1)	44	5	TO-5 detector	SMBus		
		○					Food (-20~120°C)	A1D16B-AU-50-120	16 (4x4)	88	88	TO-5 detector	SMBus		
			○				Pot surface (-20~300°C)	A3D01S-AU-50-300	1	22	22	TO-5 detector	SMBus	* Temperature drift performance improvement	<b>9</b>
				○			Thermal roller	A3D01S-CU-50-300	1	12	12	TO-5 detector	SMBus	* Focused detection	<b>15</b>
					○		Thermal roller	A3A01S-CU-33-300	1	12	12	TO-5 detector	analog	* Focused detection	<b>16</b>
9					○		Human Body temperature	TS-S2NMB-2R	1	90	90	TO-18 detector	2-channel	* Tab-less model	<b>17</b>
					○		Human Body temperature	TS-S2NMB-2RT	1	90	90	TO-18 detector	2-channel		<b>18</b>
#					○		Multi purpose	TS-S2NAB-2R	1	90	90	TO-5 detector	2-channel		<b>19</b>
					○		Multi purpose	TS-S2NAU-2C	1	12	12	TO-5 detector	2-channel		<b>20</b>

# Thermopile sensor

## A3D01S-FB-50-60

- Applications Air-conditioner  
(Floor temperature monitor)  
Target temperature -20~60°C

- Feature ASIC built-in thermopile (I2C output)  
Wide-angle detection (Single element)

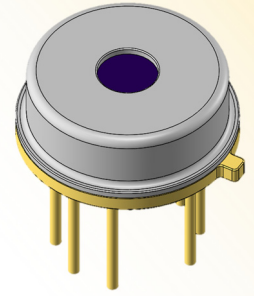

TO-5

### Dimensions

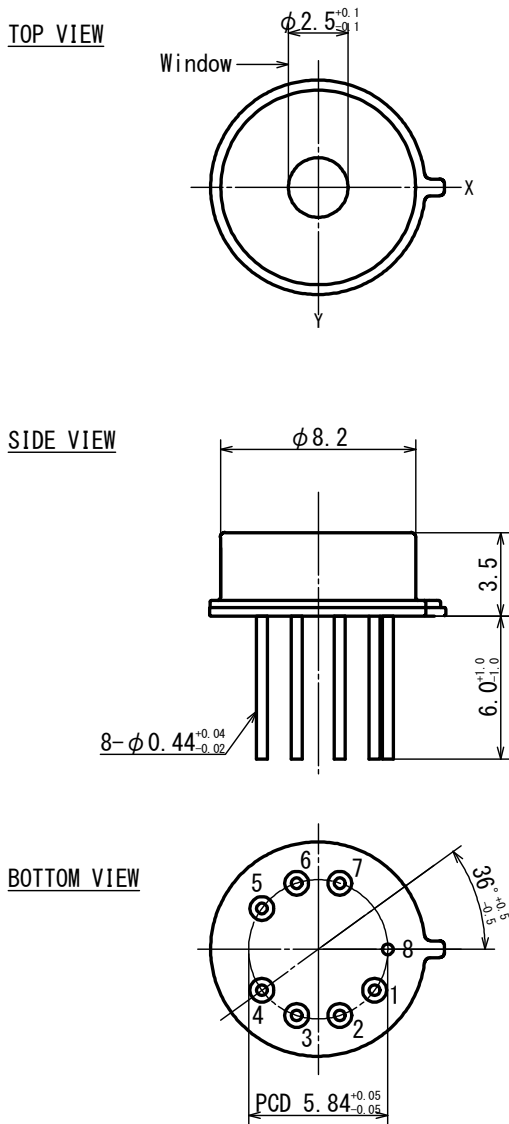

Tolerance with no specified : +/- 0.2

### FOV

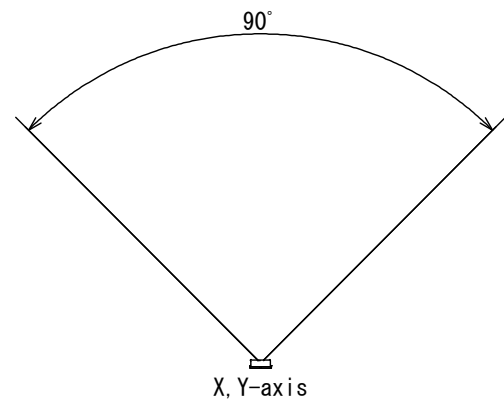

### Circuit diagram

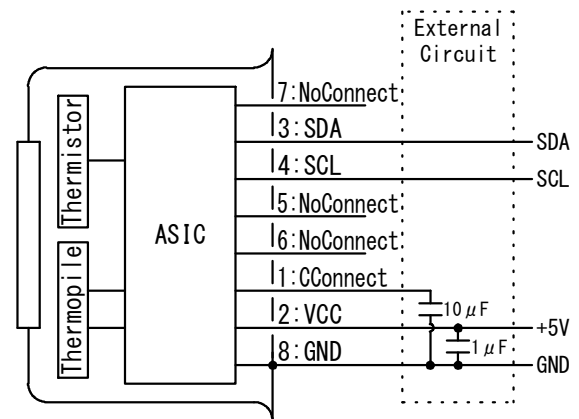

### ■ Main Parameter

Parameter	Condition	Spec.			Unit
		Min.	Typ.	Max.	
Operating Voltage		4.5	5	5.5	V
Detection Temperature		-20		400	°C
Operating Temperature		-20		100	°C
Storage Temperature		-30		105	°C
Accuracy		-2		+2	°C
Time Constant				200	msec.

# Thermopile sensor

## A3A01S-FB-33-60

- Applications **Air-conditioner**  
(Floor temperature monitor)  
Target temperature -20~60°C

- Feature **ASIC built-in thermopile (Analog output)**  
**Wide-angle detection (Single element)**

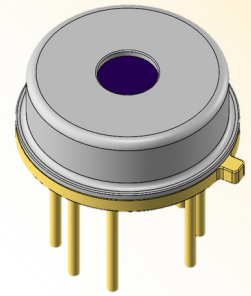

TO-5

### Dimensions

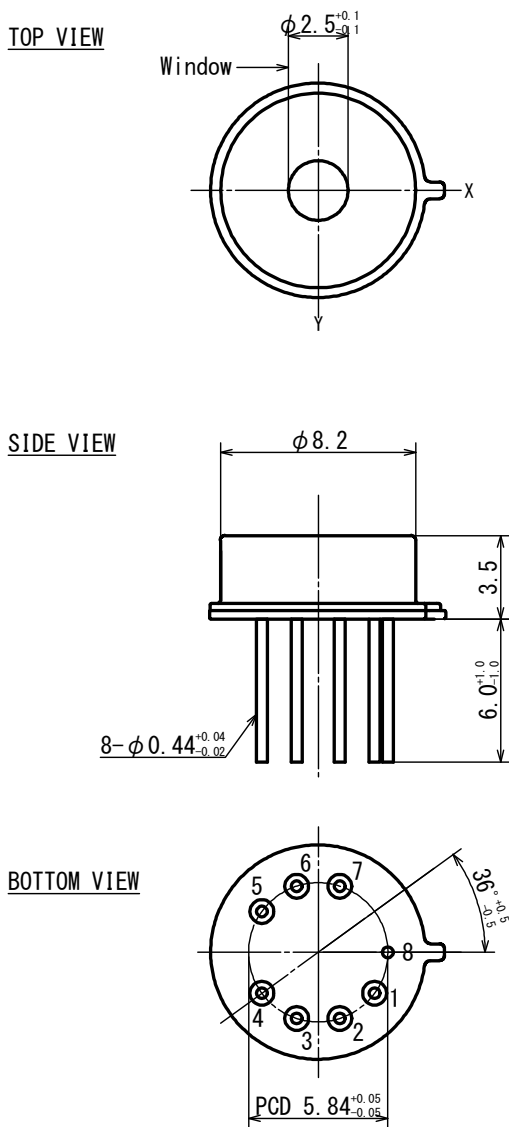

Tolerance with no specified : +/- 0.2

### FOV

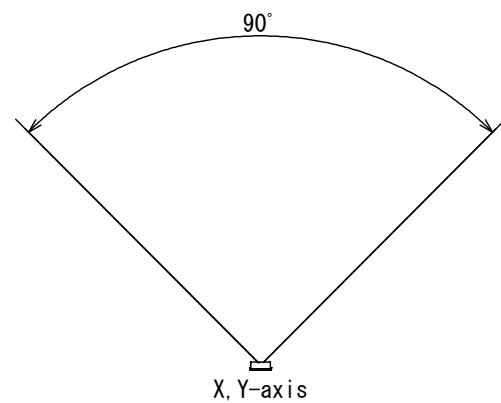

### Circuit diagram

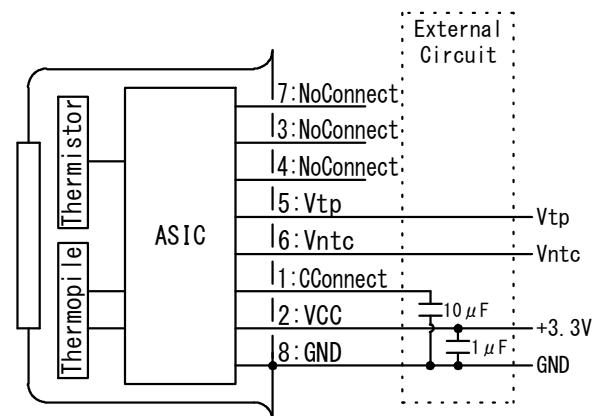

### ■ Main Parameter

Parameter	Condition	Spec.			Unit
		Min.	Typ.	Max.	
Operating Voltage		3	3.3	3.6	V
Detection Temperature		-20		60	°C
Operating Temperature		-20		100	°C
Storage Temperature		-30		105	°C
Accuracy		-2		+2	°C
Time Constant				200	msec.

# Thermopile sensor

## A1D08A-BU-50-60

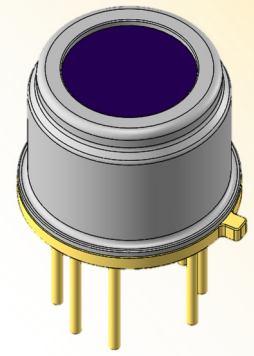

TO-5

- Applications **Air-conditioner**  
(Floor temperature monitor)  
Target temperature -20~60°C

- Feature **ASIC built-in thermopile (I2C output)**  
**8 array element**

### Dimensions

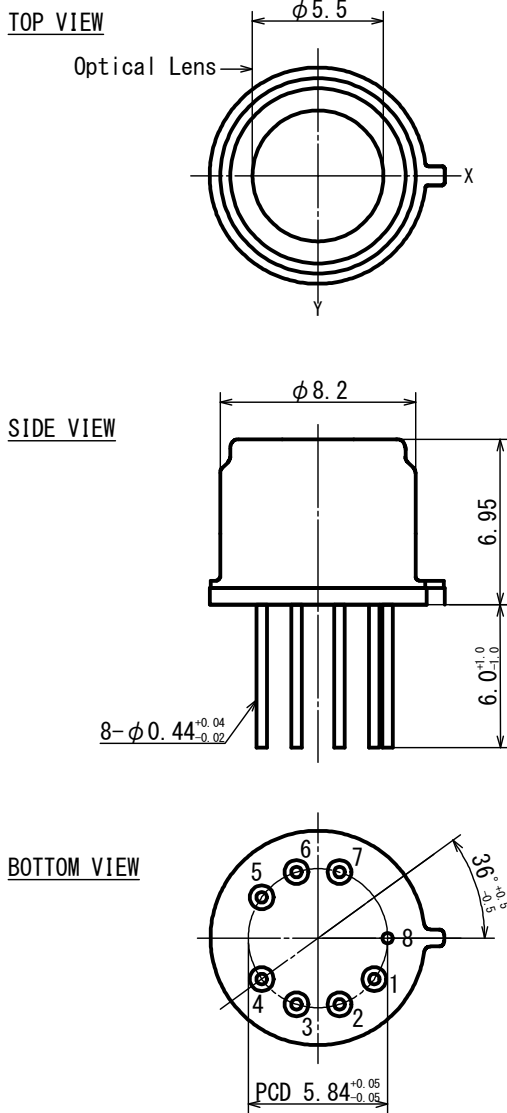

Tolerance with no specified : +/- 0.2

### FOV

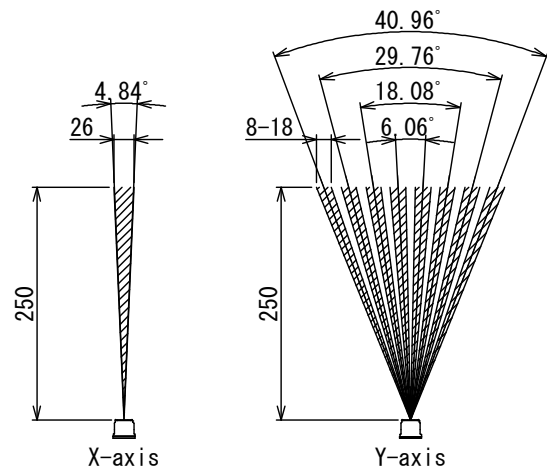

### Circuit diagram

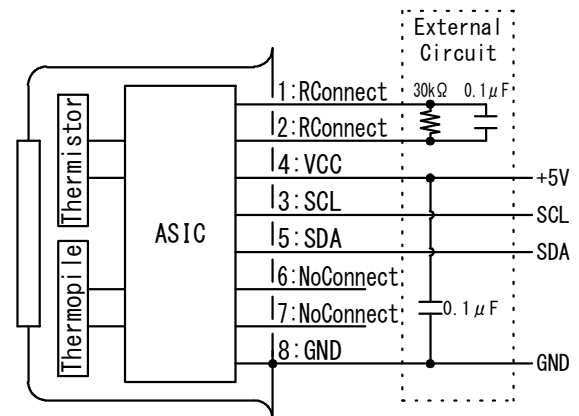

### ■ Main Parameter

Parameter	Condition	Spec.			Unit
		Min.	Typ.	Max.	
Operating Voltage		4.5	5	5.5	V
Detection Temperature		-20		60	°C
Operating Temperature		-20		100	°C
Storage Temperature		-30		105	°C
Accuracy		-2		+2	°C
Time Constant				200	msec.

Analog

Amp built-in  
ASIC built-in

SMD

Air-conditioner

Microwave  
oven

Ih cooker

Printer

Ear  
thermometer

Non-contact  
thermometer

# Thermopile sensor

## A1D16B-AU-50-60

- Applications Air-conditioner  
(Floor temperature monitor)  
Target temperature -20~60°C

- Feature ASIC built-in thermopile (I2C output)  
4 x 4 square element

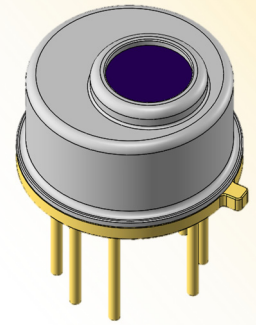

TO-5

### Dimensions

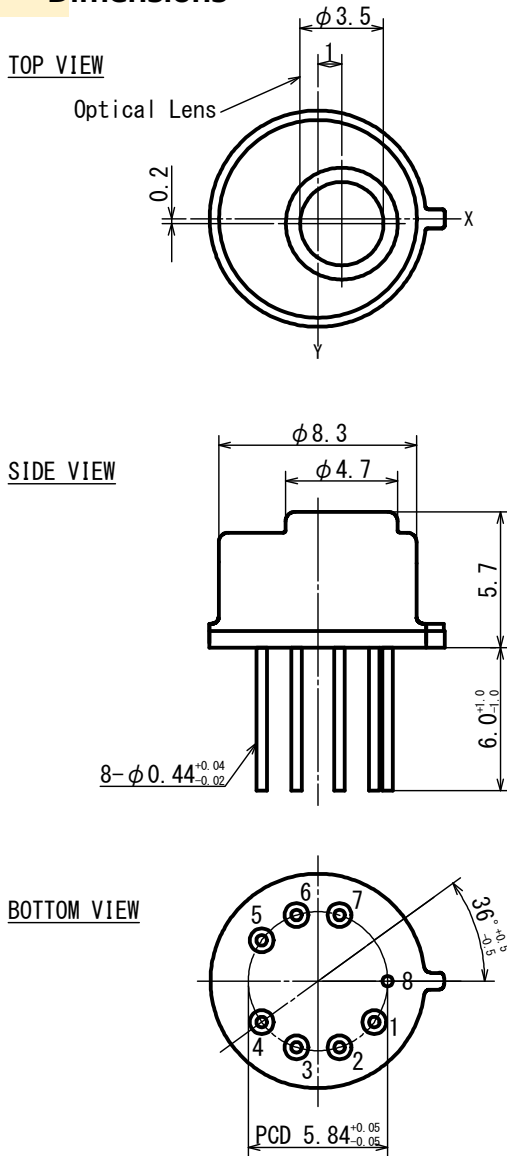

Tolerance with no specified : +/- 0.2

### FOV

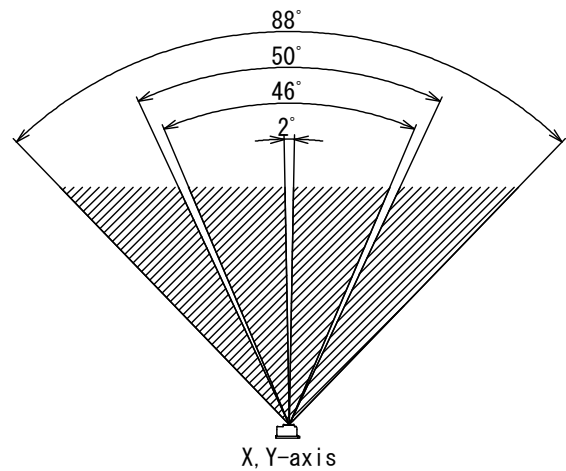

### Circuit diagram

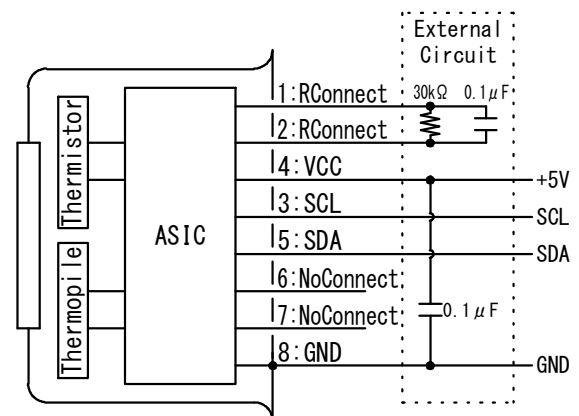

### ■ Main Parameter

Parameter	Condition	Spec.			Unit
		Min.	Typ.	Max.	
Operating Voltage		4.5	5	5.5	V
Detection Temperature		-20		60	°C
Operating Temperature		-20		100	°C
Storage Temperature		-30		105	°C
Accuracy		-2		+2	°C
Time Constant				200	msec.



# Thermopile sensor

## A3D01S-AU-50-120

- Applications **Microwave oven**  
(Food temperature detection)  
Target temperature -20~120°C

- Feature **ASIC built-in thermopile (I2C output)**  
Single element

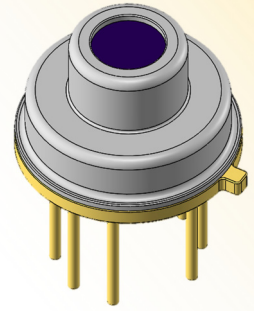

TO-5

### Dimensions

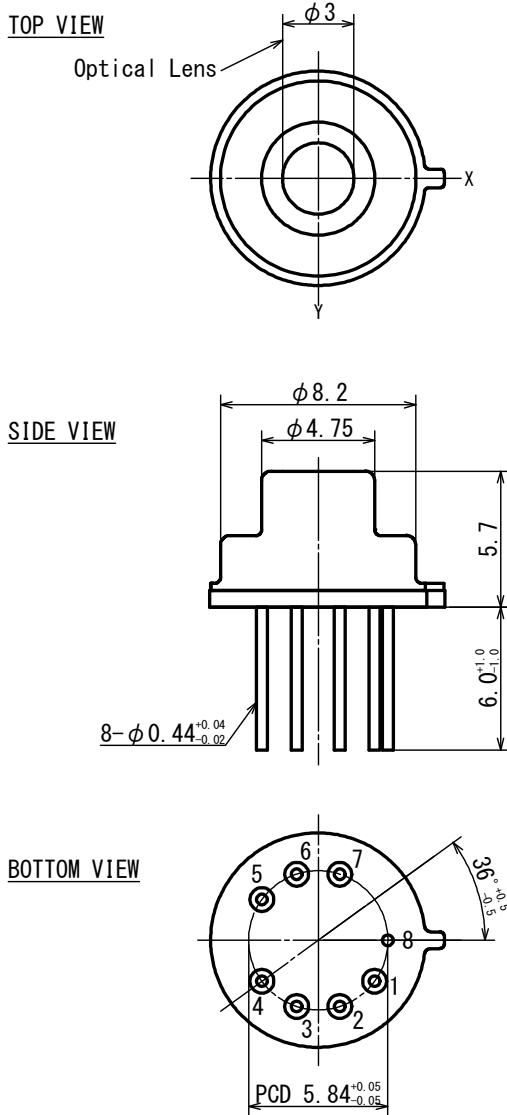

Tolerance with no specified : +/- 0.2

### FOV

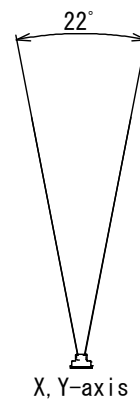

### Circuit diagram

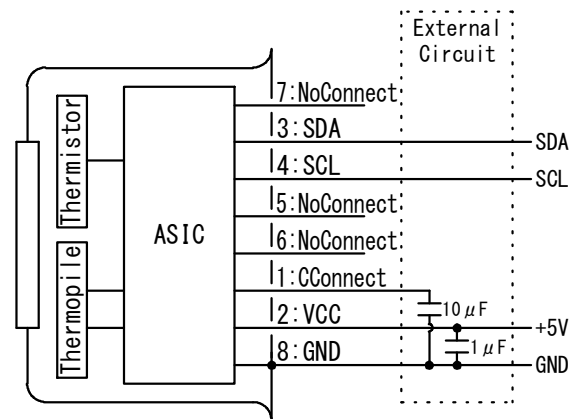

### ■ Main Parameter

Parameter	Condition	Spec.			Unit
		Min.	Typ.	Max.	
Operating Voltage		4.5	5	5.5	V
Detection Temperature		-20		400	°C
Operating Temperature		-20		100	°C
Storage Temperature		-30		105	°C
Accuracy		-2		+2	°C
Time Constant				200	msec.

Analog

Amp built-in  
ASIC built-in

SMD

Air-conditioner

Microwave oven

Ih cooker

Printer

Ear thermometer

Non-contact thermometer

# Thermopile sensor

## A3A01S-AU-33-120

- Applications **Microwave oven**  
(Food temperature detection)  
Target temperature -20~120°C

- Feature **ASIC built-in thermopile (Analog output)**  
Single element

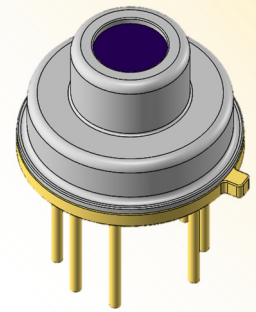

TO-5

### Dimensions

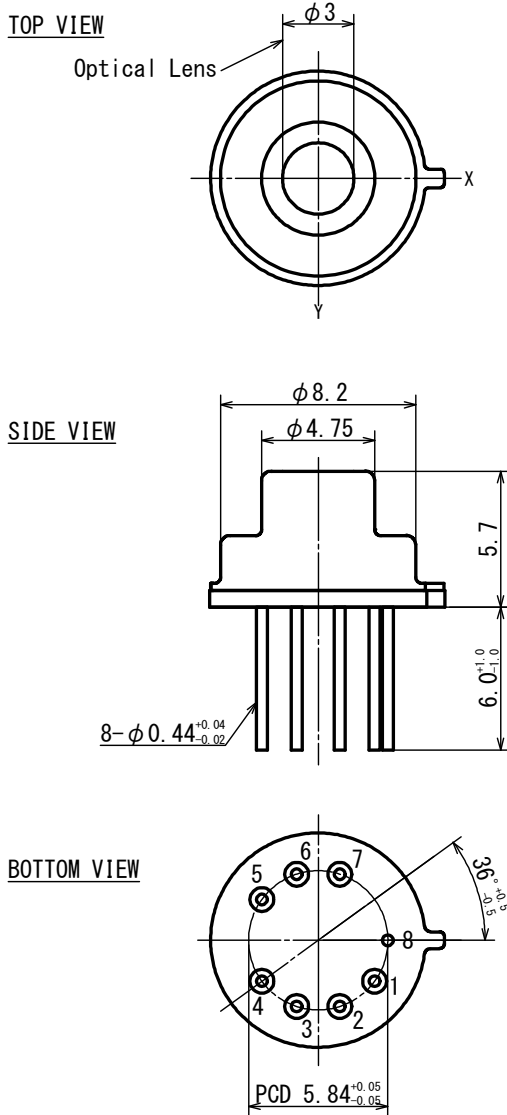

Tolerance with no specified : +/- 0.2

### FOV

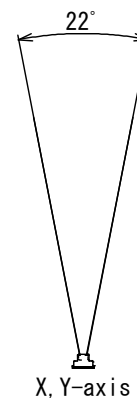

### Circuit diagram

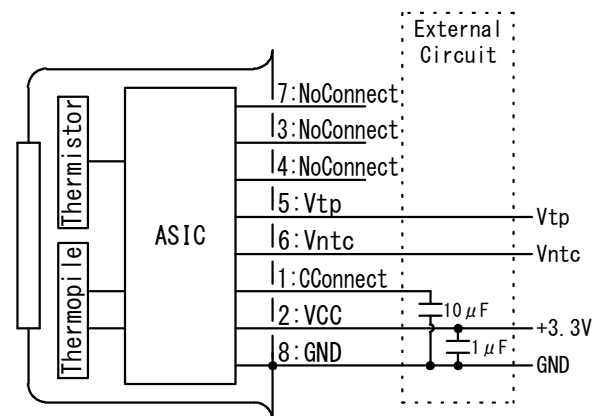

### ■ Main Parameter

Parameter	Condition	Spec.			Unit
		Min.	Typ.	Max.	
Operating Voltage		3	3.3	3.6	V
Detection Temperature		-20		120	°C
Operating Temperature		-20		100	°C
Storage Temperature		-30		105	°C
Accuracy		-2		+2	°C
Time Constant				200	msec.

# Thermopile sensor

## A1D08A-BU-50-120

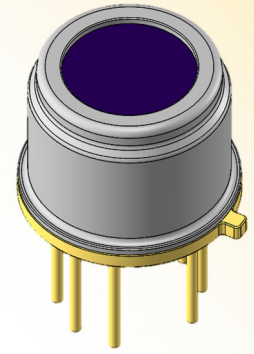

TO-5

- Applications **Microwave oven**  
(Food temperature detection)  
Target temperature -20~120°C

- Feature **ASIC built-in thermopile (I2C output)**  
**8 array element**

### Dimensions

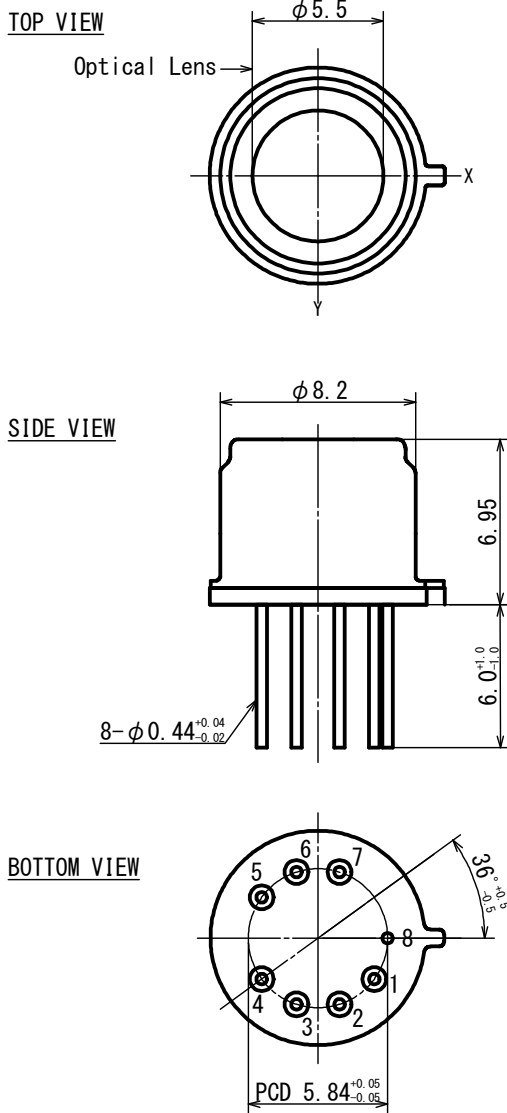

Tolerance with no specified : +/- 0.2

### FOV

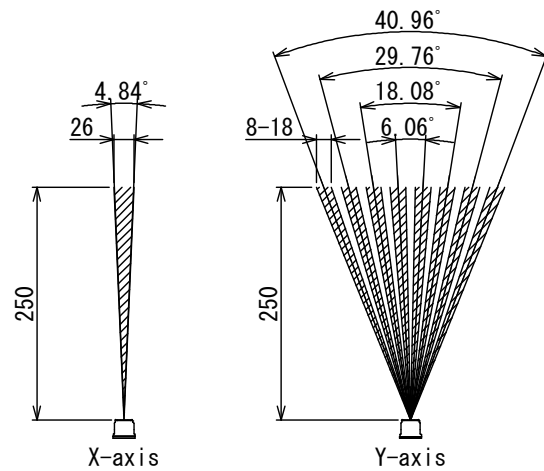

### Circuit diagram

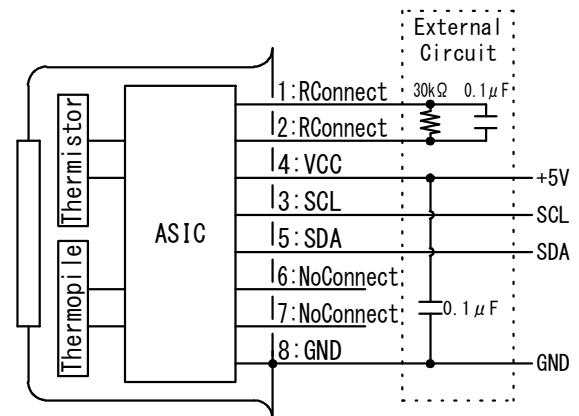

### ■ Main Parameter

Parameter	Condition	Spec.			Unit
		Min.	Typ.	Max.	
Operating Voltage		4.5	5	5.5	V
Detection Temperature		-20		120	°C
Operating Temperature		-20		100	°C
Storage Temperature		-30		105	°C
Accuracy		-2		+2	°C
Time Constant				200	msec.

Analog

Amp built-in  
ASIC built-in

SMD

Air-conditioner

Microwave oven

Ih cooker

Printer

Ear thermometer

Non-contact thermometer

# Thermopile sensor

## A1D16B-AU-50-120

- Applications **Microwave oven**  
(Food temperature detection)  
Target temperature -20~120°C

- Feature **ASIC built-in thermopile (I2C output)**  
4 x 4 square element

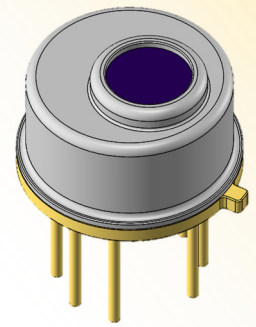

TO-5

### Dimensions

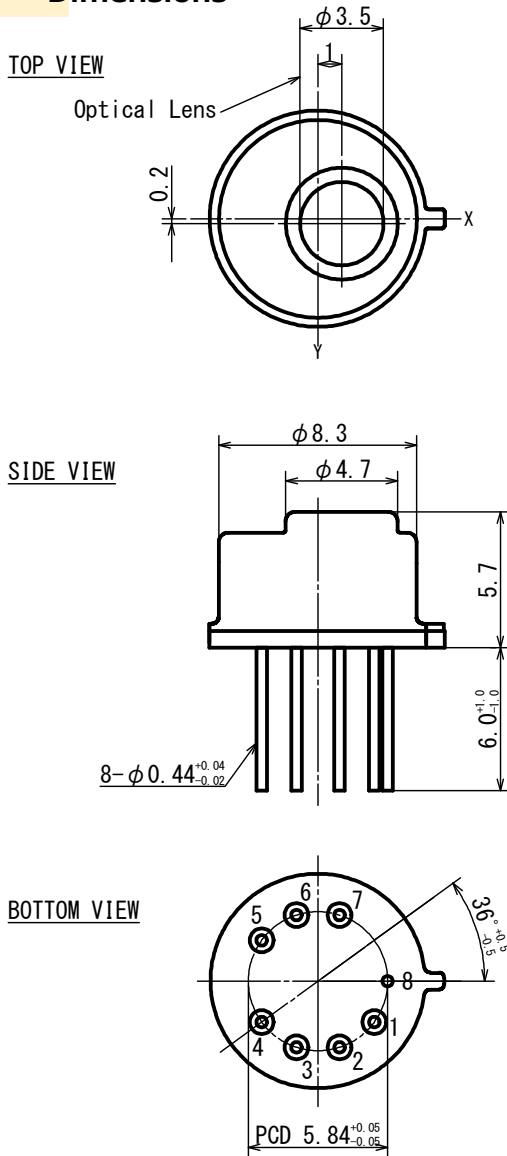

Tolerance with no specified : +/- 0.2

### FOV

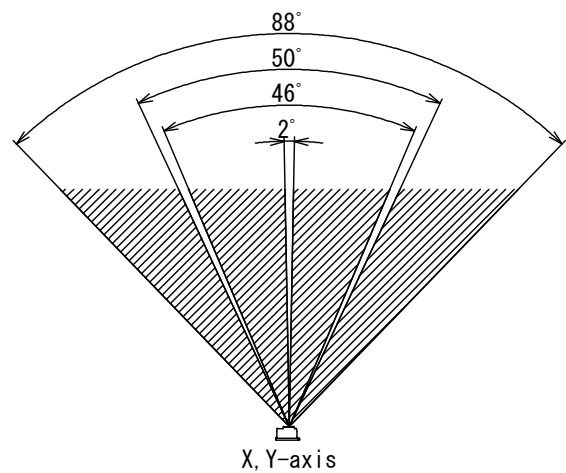

### Circuit diagram

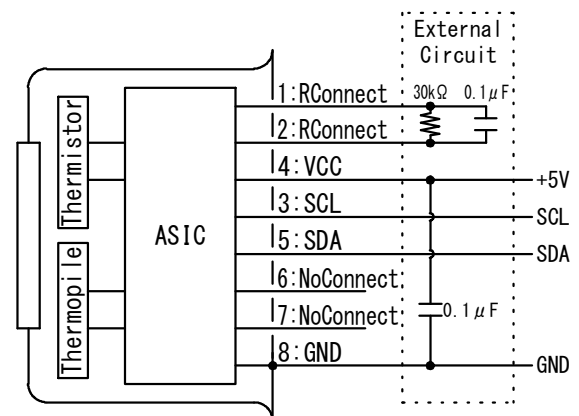

### ■ Main Parameter

Parameter	Condition	Spec.			Unit
		Min.	Typ.	Max.	
Operating Voltage		4.5	5	5.5	V
Detection Temperature		-20		120	°C
Operating Temperature		-20		100	°C
Storage Temperature		-30		105	°C
Accuracy		-2		+2	°C
Time Constant				200	msec.

# Thermopile sensor

## A3D01S-CU-50-300

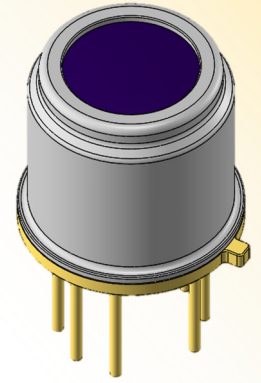

TO-5

- Applications **IH Cooker**  
(Pot surface temperature detection)  
Target temperature -20~300°C
- Feature **ASIC built-in thermopile (I2C output)**  
Focused detection (Single element)

### Dimensions

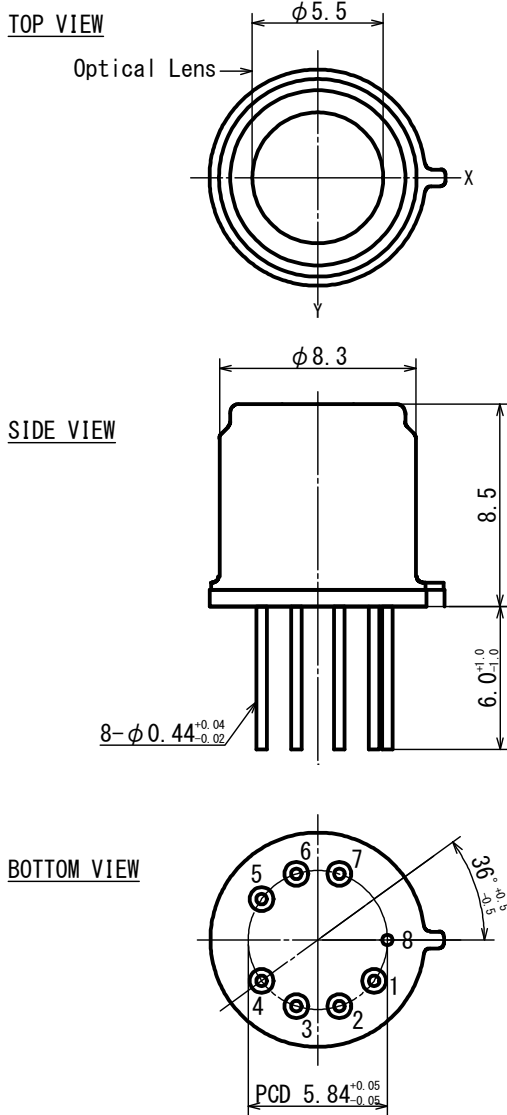

Tolerance with no specified : +/- 0.2

### FOV

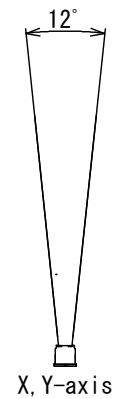

### Circuit diagram

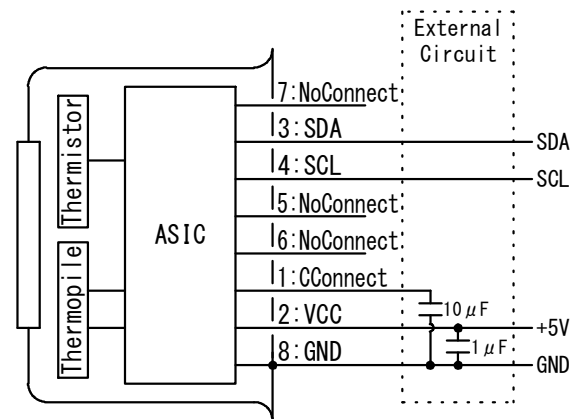

### ■ Main Parameter

Parameter	Condition	Spec.			Unit
		Min.	Typ.	Max.	
Operating Voltage		4.5	5	5.5	V
Detection Temperature		-20		400	°C
Operating Temperature		-20		100	°C
Storage Temperature		-30		105	°C
Accuracy		-3		+3	°C
Time Constant				200	msec.

Analog

Amp built-in  
ASIC built-in

SMD

Air-conditioner

Microwave oven

Ih cooker

Printer

Ear thermometer

Non-contact thermometer

# Thermopile sensor

## A3A01S-CU-33-300

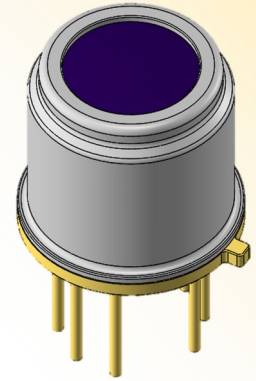

TO-5

- Applications **IH Cooker**  
(Pot surface temperature detection)  
Target temperature -20~300°C

- Feature **ASIC built-in thermopile (Analog output)**  
Focused detection (Single element)

### Dimensions

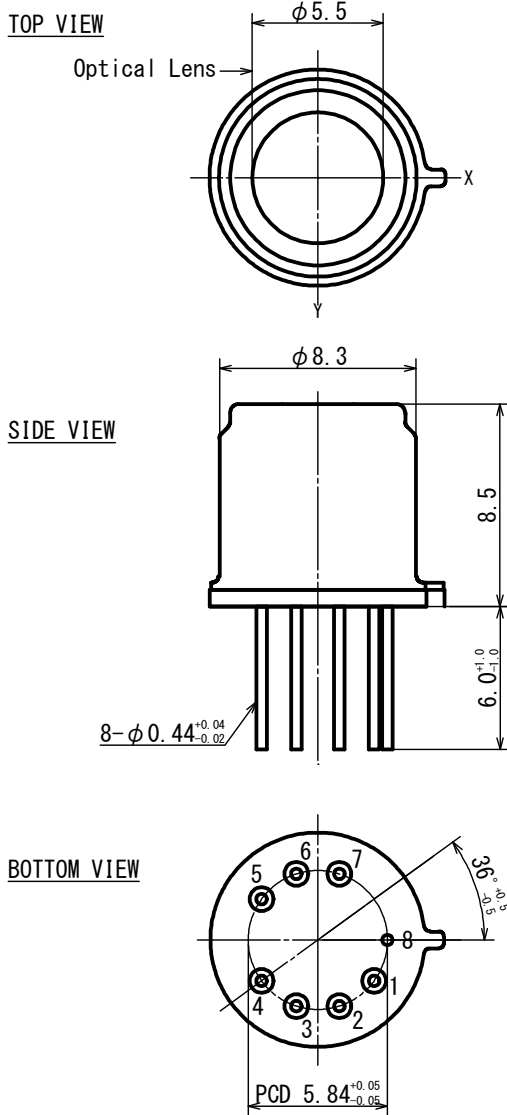

Tolerance with no specified : +/- 0.2

### FOV

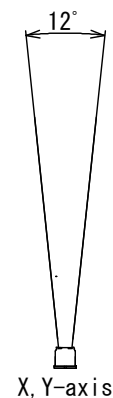

### Circuit diagram

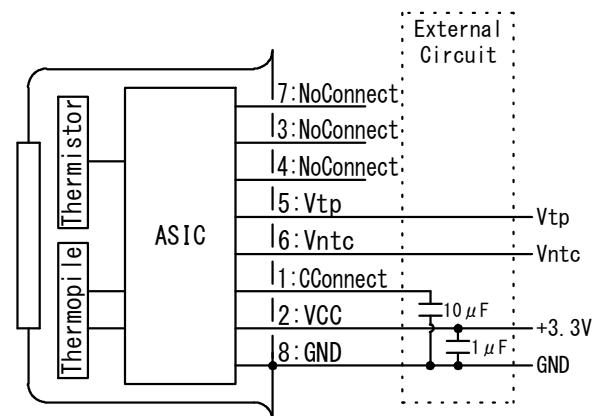

### ■ Main Parameter

Parameter	Condition	Spec.			Unit
		Min.	Typ.	Max.	
Operating Voltage		3	3.3	3.6	V
Detection Temperature		-20		300	°C
Operating Temperature		-20		100	°C
Storage Temperature		-30		105	°C
Accuracy		-3		+3	°C
Time Constant				200	msec.

# Thermopile sensor



## A3D01S-CU-50-300

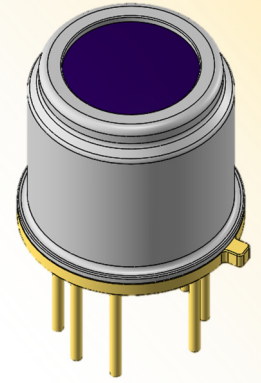

TO-5

■ Applications **Printer**  
(Thermal roller temperature detection)

■ Feature **ASIC built-in thermopile (I2C output)**  
**Focused detection (Single element)**

### Dimensions

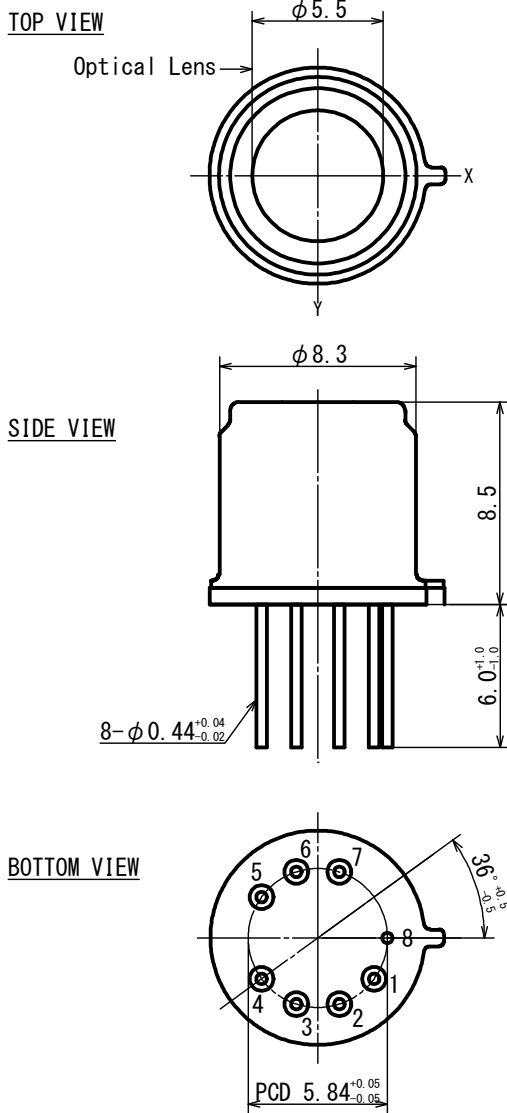

Tolerance with no specified : +/- 0.2

### FOV

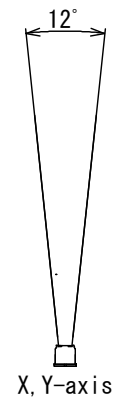

### Circuit diagram

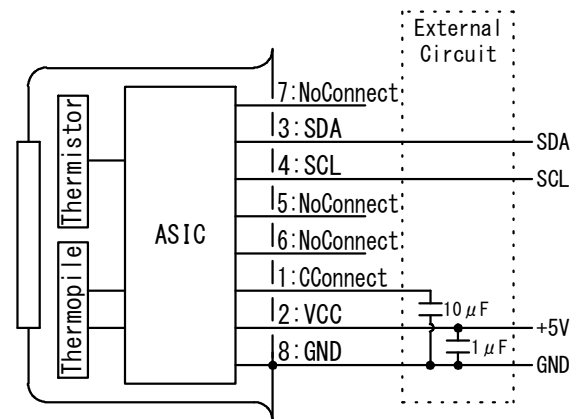

### ■ Main Parameter

Parameter	Condition	Spec.			Unit
		Min.	Typ.	Max.	
Operating Voltage		4.5	5	5.5	V
Detection Temperature		-20		400	°C
Operating Temperature		-20		100	°C
Storage Temperature		-30		105	°C
Accuracy		-3		+3	°C
Time Constant				200	msec.

Analog

Amp built-in  
ASIC built-in

SMD

Air-conditioner

Microwave oven

Ih cooker

Printer

Ear thermometer

Non-contact thermometer

# Thermopile sensor

## A3A01S-CU-33-300

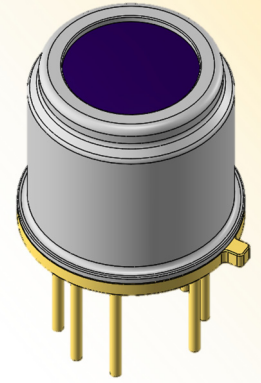

TO-5

■ Applications **Printer**  
(Thermal roller temperature detection)

■ Feature **ASIC built-in thermopile (Analog output)**  
**Focused detection (Single element)**

### Dimensions

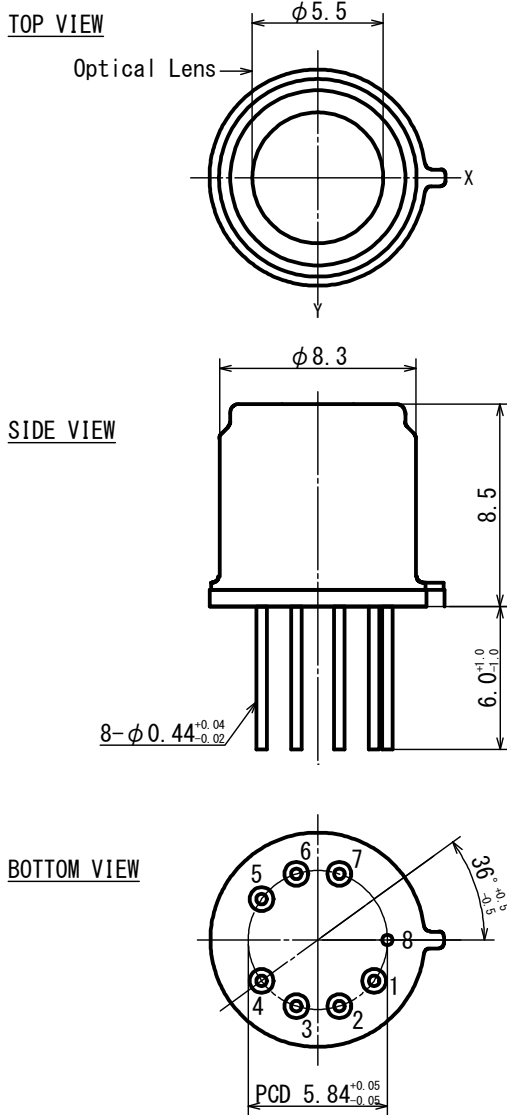

Tolerance with no specified : +/- 0.2

### FOV

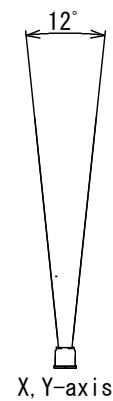

### Circuit diagram

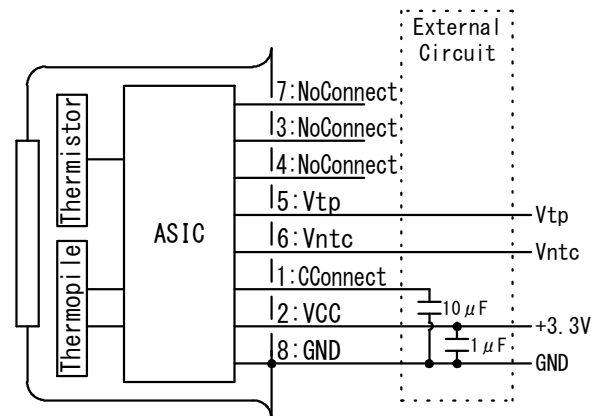

### ■ Main Parameter

Parameter	Condition	Spec.			Unit
		Min.	Typ.	Max.	
Operating Voltage		3	3.3	3.6	V
Detection Temperature		-20		300	°C
Operating Temperature		-20		100	°C
Storage Temperature		-30		105	°C
Accuracy		-3		+3	°C
Time Constant				200	msec.



# Thermopile sensor

## TS-S2NMB-2R

■ Applications Ear thermometer  
(Human body temperature detection)

■ Feature Object-Sensor temperature detection  
(2-channel)  
Single element, Tab-less model

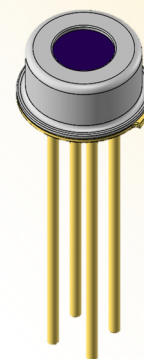

TO-18

### Dimensions

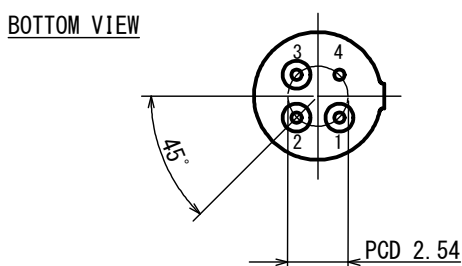
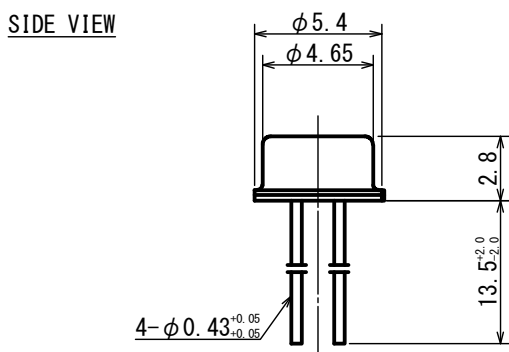
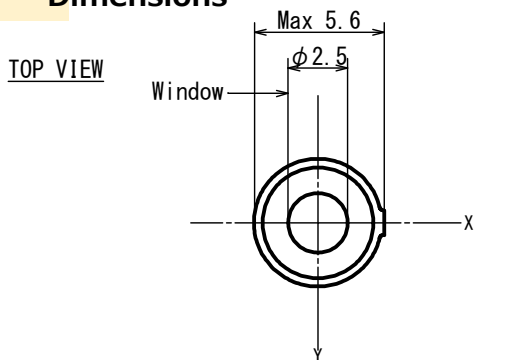

Tolerance with no specified : +/- 0.2

### FOV

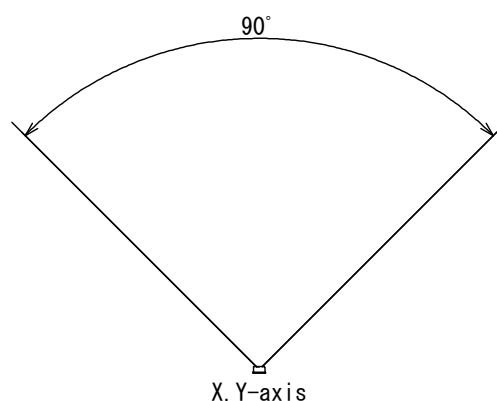

### Circuit diagram

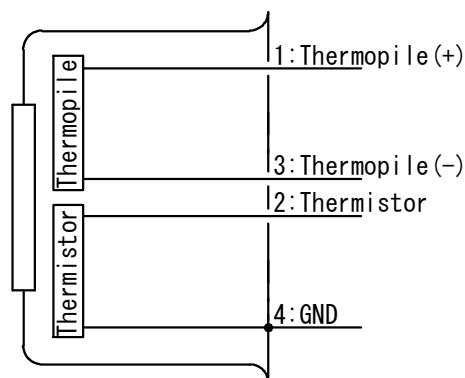

### ■ Main Parameter

Parameter	Condition	Spec.			Unit
		Min.	Typ.	Max.	
Sensitivity Output	323K at shutter opening	1.82	2.43	3.03	mV
Resistance of thermopile		145	175	205	kΩ
Thermistor resistor	25°C	95	100	105	kΩ
Operating Temperature		-30		100	°C
Time Constant		25	50	80	msec.

Analog

Amp build-in  
ASIC build-in

SMD

Air-conditioner

Microwave oven

Ih cooker

Printer

Ear thermometer

Non-contact thermometer

# Thermopile sensor

## TS-S2NMB-2RT

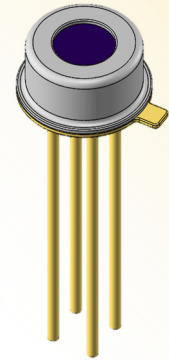

TO-18

■ Applications Ear thermometer  
(Human body temperature detection)

■ Feature Object-Sensor temperature detection  
(2-channel)  
Single element

### Dimensions

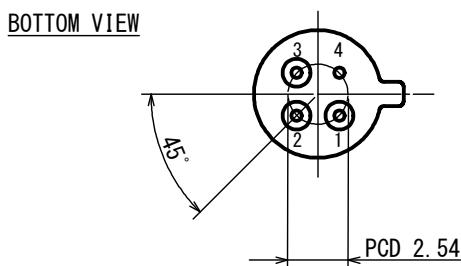
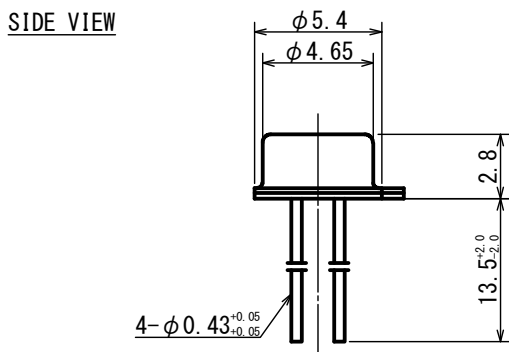
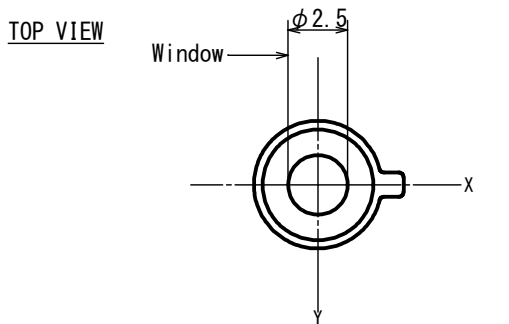

Tolerance with no specified : +/- 0.2

### FOV

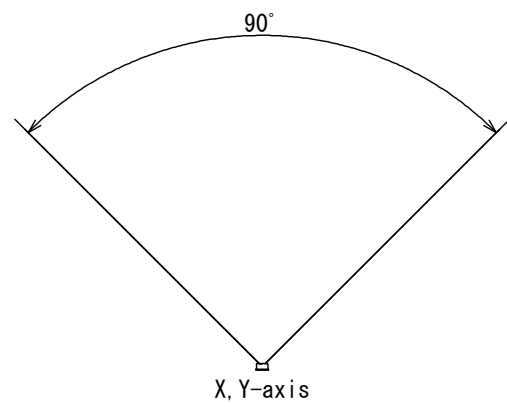

### Circuit diagram

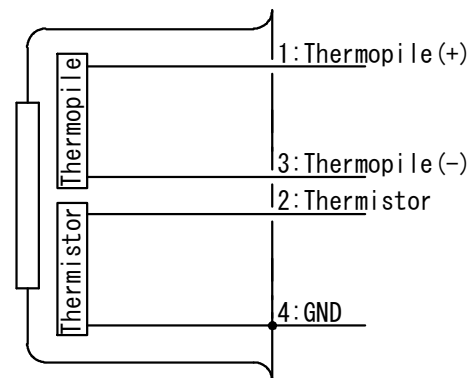

### ■ Main Parameter

Parameter	Condition	Spec.			Unit
		Min.	Typ.	Max.	
Sensitivity Output	323K at shutter opening	1.82	2.43	3.03	mV
Resistance of thermopile		145	175	205	kΩ
Thermistor resistor	25°C	95	100	105	kΩ
Operating Temperature		-30		100	°C
Time Constant		25	50	80	msec.

# Thermopile sensor TS-S2NAB-2R

■ Applications Non-contact thermometer

■ Feature Object-Sensor temperature detection (2-channel)  
Wide-angle detection (Single element)

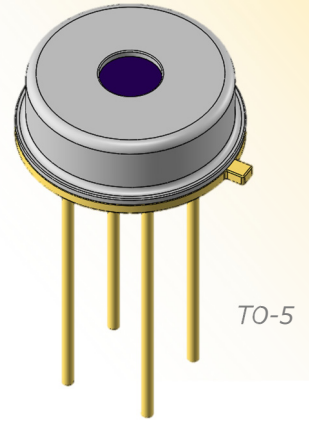

## Dimensions

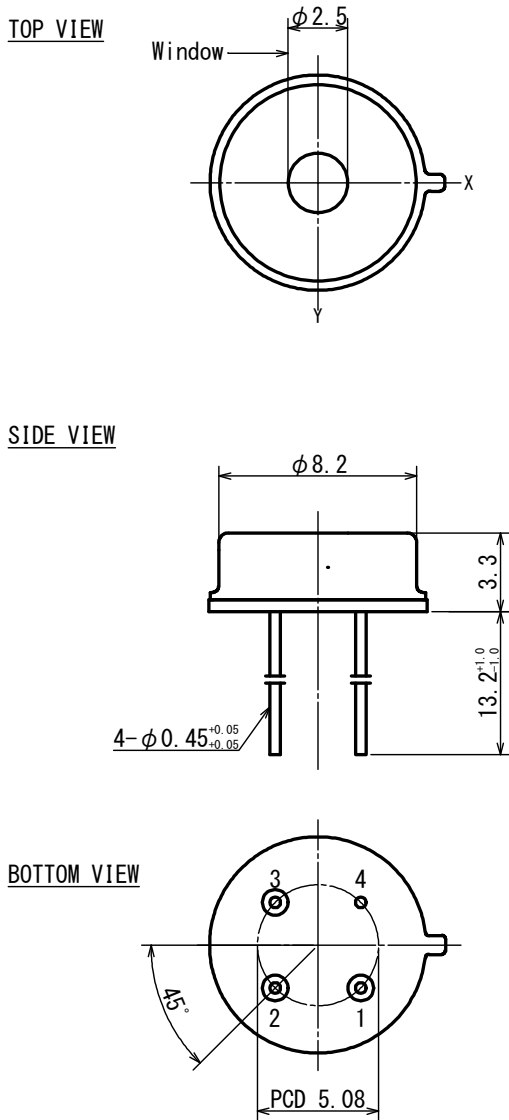

Tolerance with no specified : +/- 0.2

## FOV

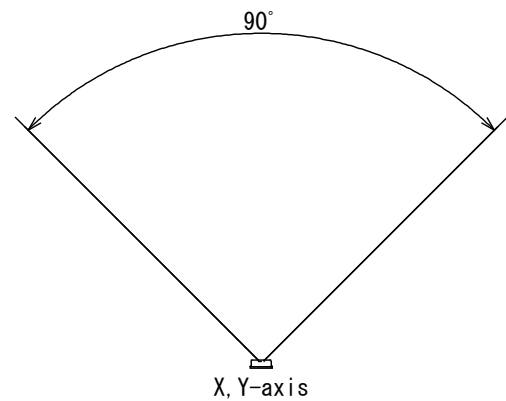

## Circuit diagram

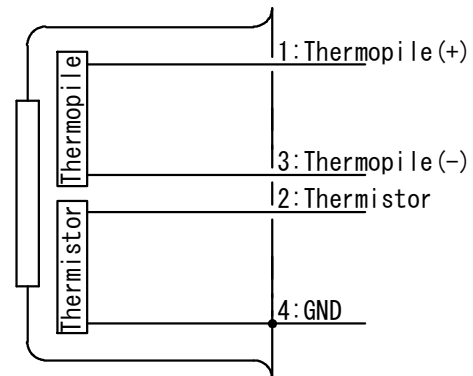

## ■ Main Parameter

Parameter	Condition	Spec.			Unit
		Min.	Typ.	Max.	
Sensitivity Output	323K at shutter opening	1.5	2	2.5	mV
Resistance of thermopile		145	175	205	kΩ
Thermistor resistor	25°C	95	100	105	kΩ
Operating Temperature		-30		100	°C
Time Constant		25	50	80	msec.

Analog

Amp build-in  
ASIC build-in

SMD

Air-conditioner

Microwave oven

Ih cooker

Printer

Ear thermometer

Non-contact thermometer

# Thermopile sensor TS-S2NAU-2C

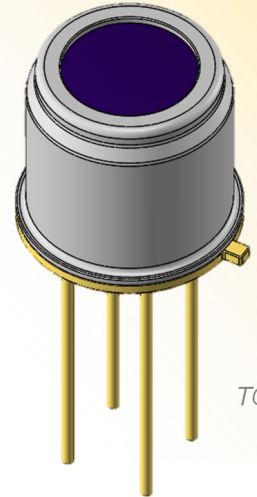

■ Applications Non-contact thermometer

■ Feature Object-Sensor temperature detection (2-channel)  
Focused detection (Single element)

## Dimensions

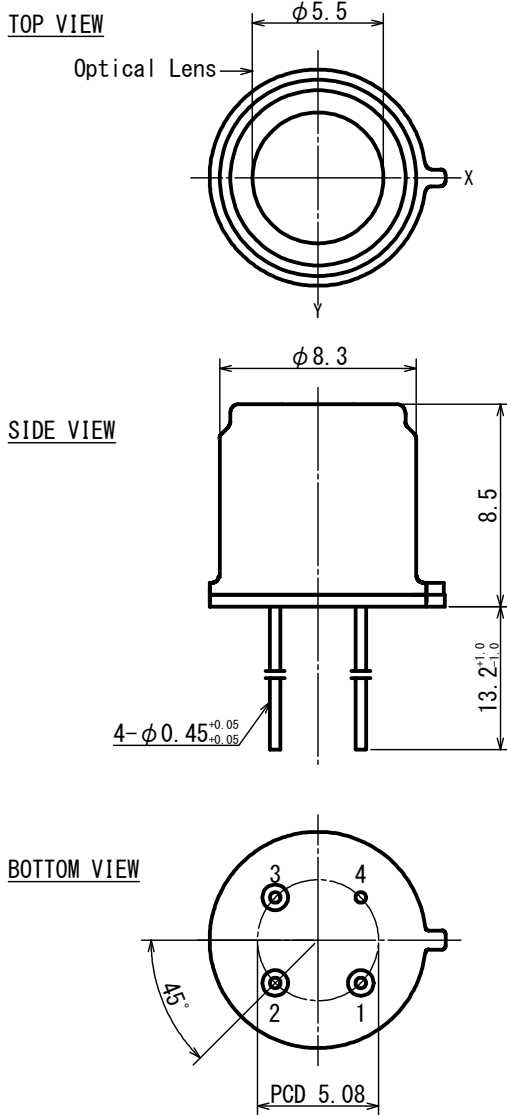

Tolerance with no specified : +/- 0.2

## FOV

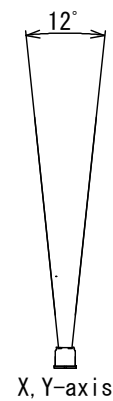

## Circuit diagram

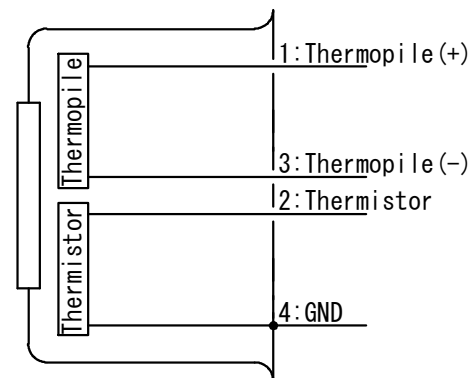

## ■ Main Parameter

Parameter	Condition	Spec.			Unit
		Min.	Typ.	Max.	
Sensitivity Output	323K at shutter opening	0.42	0.57	0.71	mV
Resistance of thermopile		145	175	205	kΩ
Thermistor resistor	25°C	95	100	105	kΩ
Operating Temperature		-30		100	°C
Time Constant		25	50	80	msec.

1. Design restrictions/precautions

These sensors are designed for indoor use. If used for outdoor applications, please be sure to apply proper supplementary optical filter, drip-proof and anti-dew construction.

In cases where secondary accidents caused by operation failure or malfunction of the sensor could be expected, please include a fail safe function into the design.

2. Remarks

These sensors are not suitable for applications that require extremely high reliability, such as related to human life (life supporting devices and etc.).

These sensors must not be used for products that are prohibited to manufacture, use and sell by Japanese domestic and foreign laws and orders.

The contents described in this catalog are as of January 2021.

The described contents may be changed or suspended without notice.

Agent:Real Chance Co.,Ltd Taiwan:+886-2-2908-8287 China:+86-0769-82388628  
<http://www.realchance.com.tw>

## Nippon Ceramic Co., Ltd.

### Technical Center

176-17, Hirooka,  
Tottori-shi 689-1193 JAPAN  
TEL +81-857-53-3600  
(Pilot)  
FAX +81-857-53-3676  
Mail [ip-sales@nicera.co.jp](mailto:ip-sales@nicera.co.jp)

<https://www.nicera.co.jp/>

### Nicera European Works Ltd.

- NEW -  
25 Copinger Close, Totton,  
Southampton, Hants,  
SO40 8WN United Kingdom  
TEL +44-2380-667908  
FAX +44-2380-663758

### Nicera Hong Kong Ltd.

- NHK -  
Unit L1, 5/F, Phase 2,  
Kaiser Estate,  
NOS 47-53 Man Yue Street,  
Hung Hom, Kowloon,  
Hong Kong, China  
TEL +852-2795-7511  
FAX +852-2754-3957

### Nicera America Corp.

- NAC -  
16461 Sherman Way,  
Suite 248, Van Nuys,  
CA 91406, USA  
TEL +1-818-779-2100  
FAX +1-818-779-2111